

Essentra Components does not warrant that the files will be error free and may create new versions ("Upgrades") at any time, which may correct such errors. Essentra Components has no obligation to notify you of such upgrades. Any upgraded file will be published to the website, when it becomes available.

You are not permitted to load any of the files on to a network server for the purposes of distribution to one or more other computer(s) on that network or to effect such distribution. Essentra Components shall not be liable for any loss or damage whatsoever or however caused, arising directly or indirectly from the use of the files.

UNCONTROLLED COPY

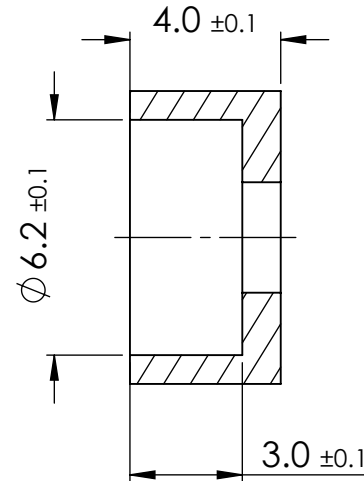
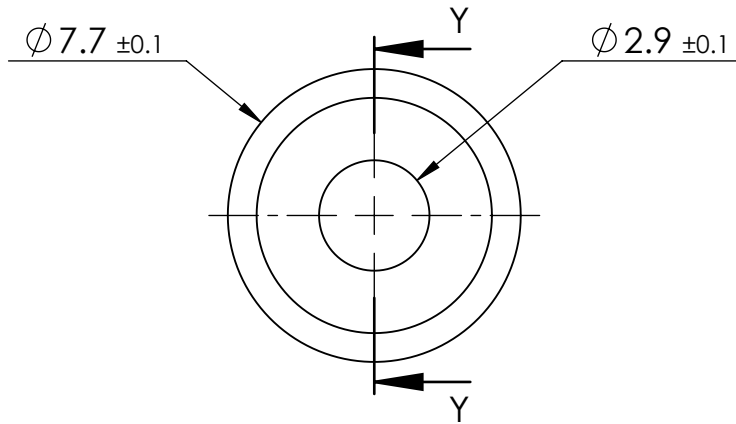

SECTION Y-Y

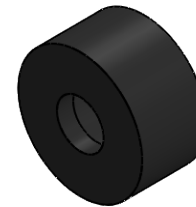

3:1

STATUS **APPROVED DRAWING**

UNLESS OTHERWISE STATED

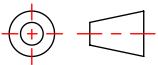
ALL DIMENSIONS IN mm			DO NOT SCALE	
LINEAR TOLERANCE			THIRD ANGLE PROJECTION	
SIZE	(0)	(0.0)	(0.00)	 ANGULAR TOLERANCE ± 0.5 DEGREES UNSPECIFIED RADII 0.25mm DRAFT ANGLE 0.5 DEGREES DIMENSIONS IN PARENTHESIS () ARE FOR REFERENCE ONLY
0-10	± 0.5	± 0.15	± 0.10	
>10-30	± 0.5	± 0.20	± 0.15	
>30-50	± 0.5	± 0.30	± 0.20	
>50-100	± 0.8	± 0.50	± 0.25	
>100-200	± 1.5	± 0.80	± 0.40	
>200-300	± 2.0	± 1.20	± 0.80	
>300-500	± 3.0	± 2.00	± 1.00	
>500	± 5.0	± 3.00	± 1.50	

ITEM CODE	20442187	10.03.2025	CREATE DATE
LEGACY CODE	16CW004040B	PA66	MATERIAL
		BLACK	COLOUR
		-	FINISH

TITLE:
 CUPPED WASHER
 -

DWG. No.	20442187	SCALE	5:1	ISSUE	1
		SHEET	1 of 2		

Essentra Components does not warrant that the files will be error free and may create new versions ("Upgrades") at any time, which may correct such errors. Essentra Components has no obligation to notify you of such upgrades. Any upgraded file will be published to the website, when it becomes available.

You are not permitted to load any of the files on to a network server for the purposes of distribution to one or more other computer(s) on that network or to effect such distribution. Essentra Components shall not be liable for any loss or damage whatsoever or however caused, arising directly or indirectly from the use of the files.

UNCONTROLLED COPY

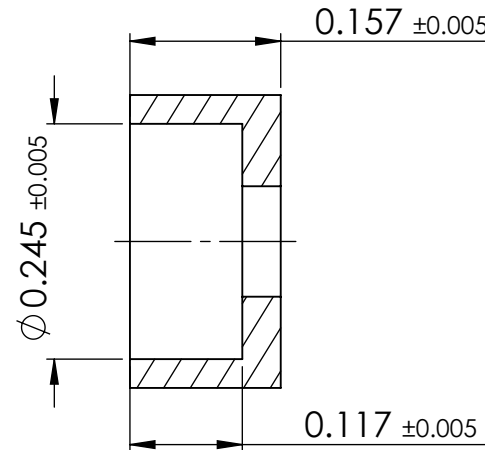
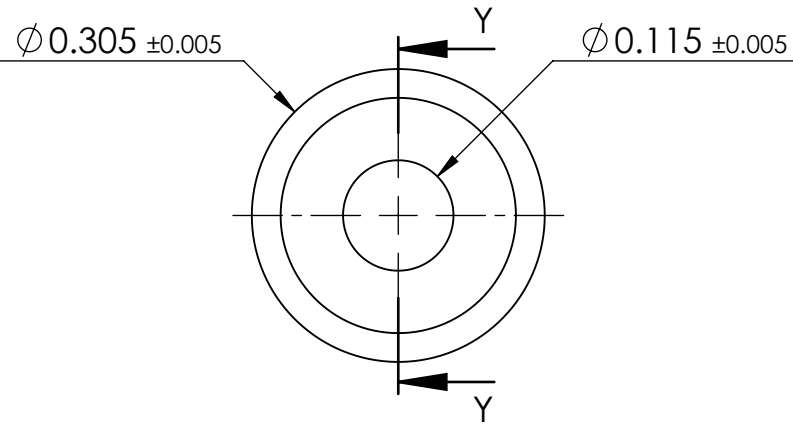

SECTION Y-Y

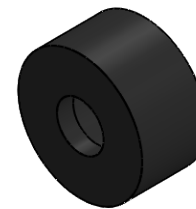

3:1

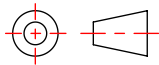
STATUS		APPROVED DRAWING	
UNLESS OTHERWISE STATED			
ALL DIMENSIONS IN inches		DO NOT SCALE	
LINEAR TOLERANCE		THIRD ANGLE PROJECTION	
SIZE	(0.00) (0.000) (0.0000)		
0 - 0.394	±0.020 ±0.006 ±0.004	ANGULAR TOLERANCE ±0.5 DEGREES	
>0.394 - 1.181	±0.020 ±0.008 ±0.006	UNSPECIFIED RADIUS 0.25mm	
>1.181 - 1.969	±0.020 ±0.012 ±0.008	DRAFT ANGLE 0.5 DEGREES	
>1.969 - 3.937	±0.031 ±0.020 ±0.010	DIMENSIONS IN PARENTHESIS () ARE FOR REFERENCE ONLY	
>3.937 - 7.874	±0.059 ±0.031 ±0.016		
>7.874 - 11.811	±0.079 ±0.047 ±0.031		
>11.811 - 19.685	±0.118 ±0.079 ±0.039		
>19.685	±0.197 ±0.118 ±0.059		
ITEM CODE	20442187	CREATE DATE	10.03.2025
LEGACY CODE	16CW004040B	MATERIAL	PA66
		COLOUR	BLACK
		FINISH	-
TITLE: CUPPED WASHER -			
DWG. No.	20442187	SCALE	5:1
		ISSUE	1
		SHEET	2 of 2